



Shielded lamps and connection cables

A step towards healthier living and working

■ Why shielding against electric and magnetic fields?

Electric and magnetic fields occur everywhere. Their origin is both natural and artificial. Artificially generated fields in particular are becoming increasingly important.

The use of electrical and electronic devices in the living and working environment is constantly increasing.

The influence of artificially generated fields on the human organism has not yet been conclusively researched, but there is increasing note that people react sensitively to exposure to electric and/or magnetic fields.

Electric fields are basically caused by every electric line, even if a connected device is not switched on. This field can be almost completely eliminated by using shielded components, without having to sacrifice comfort.

Magnetic fields only occur when a device / lamp is also switched on and thus a current flows. Magnetic fields can also be significantly reduced by the appropriate design of a lamp.

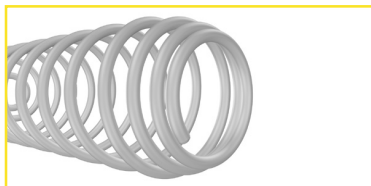
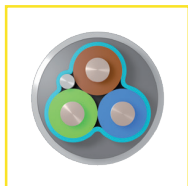

■ Practical construction of shielded lamps

Our shielded lamps basically consist of a three-pole connecting cable, a metal lamp housing of protection class I and a shielding basket for the light source.

While conventional mains cables are usually designed with two poles and a Euro plug, our cables have three poles (with protective conductor, increased safety) and are equipped with a metallic sheathing of the core as a shield.

Our lamps have a metallic housing (or inner housing in the case of lamps made of wood) which, unlike other materials such as plastic or wood, also shields against the alternating electric field.

Lamp socket and light source (according to building biology recommendations) were integrated into the shielded system by means of a shielding basket, as considerable alternating electric fields can be measured here as well without shielding.

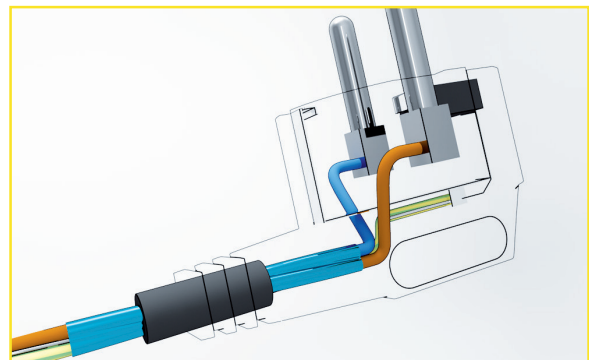

Shielding effect in comparison

An unshielded lamp (protection class 2) with an unshielded connecting cable produces an alternating electric field of 100.0 to 160.0 V/m (building biology recommended guide value 10.0 V/m). The shielded lamp (protection class 1) with a corresponding construction only produces an alternating electric field of a minimum of 0.4 to 0.6 V/m.

The screening is checked according to the specifications, frequency bands and measuring distances of the recognised screen standards (for low-radiation screens / monitors): TCO'99, Band I (MPR II) and DIN EN 50279 (measuring distance 30 cm)..

What else can be done?

- Only use shielded connection cables and socket strips for your other devices!
- Never leave appliances switched on or in stand-by mode for longer than necessary; always unplug the appropriate mains plug or switch off two-pole.
- Avoid electrical appliances in your bedrooms or living rooms or place them as far away from you as possible.

Generally useful notes on the subject of „electrosmog“ can be found on the Internet at:

www.verband-baubiologie.de
www.baubiologie.net
www.baubiologie.de

All product information on shielded cables, connecting cables, socket strips and lamp systems can be found under: www.biologadanell.com.



Table lamp AMSTERDAM - Instruction manual

TABLE LAMP AMSTERDAM - 400058



■ Initial operation

1. Remove packaging material
2. Insert G9 light source
3. Connect the cable to the socket
4. Switching on and off with ON / OFF switch

■ Changing the light source

Attention, important note:

For all work on the lamp, always disconnect the mains plug first!

Press the screen basket down from above

1. Remove the defective lamp and insert the new lamp. Let the lampshade basket slowly escape upwards under its own power.

■ Insert G9 light source / change light source G9

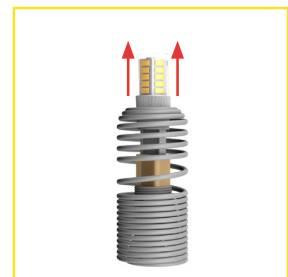
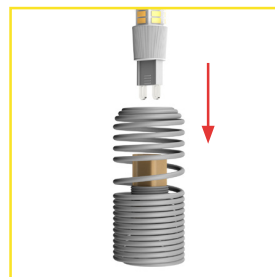
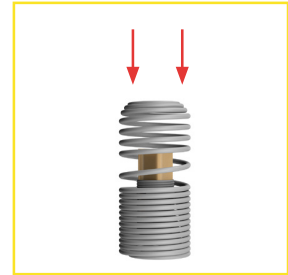
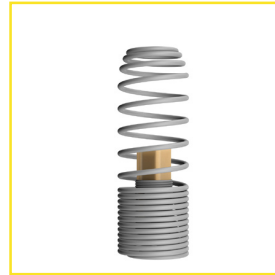
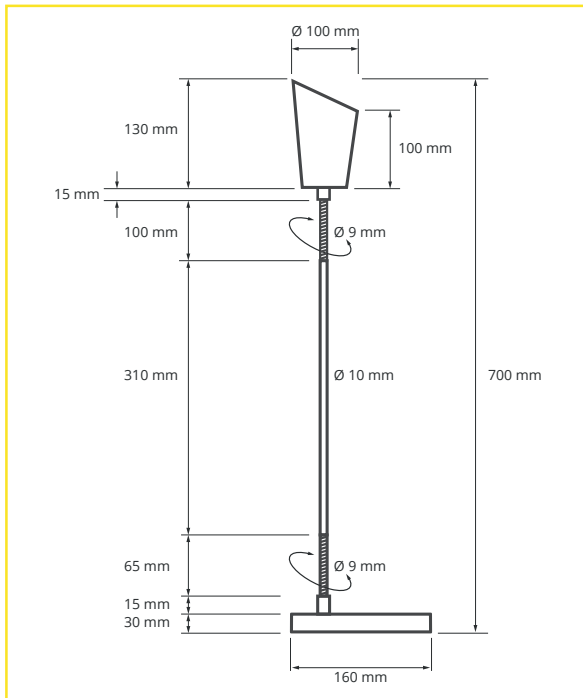

Safety instructions

All electrical work (work on electrical equipment and installations) must be carried out and inspected by a qualified electrician or under their direction and supervision!

Use your lamp only in normally tempered, dry indoor rooms. No outdoor use!

